

PAPERS | APRIL 01 1993

A magnetic suspension system for atoms and bar magnets



C. Sackett; E. Cornell; C. Monroe; C. Wieman



Am. J. Phys. 61, 304–309 (1993)

<https://doi.org/10.1119/1.17261>



Articles You May Be Interested In

Mathieu functions describing particles evolving in electromagnetic waves

AIP Conference Proceedings (December 2017)

Characterization of a levitated sub-milligram ferromagnetic cube in a planar alternating-current magnetic Paul trap

Appl. Phys. Lett. (September 2024)

Applications of the Mathieu equation

American Journal of Physics (January 1996)



Learn about the newest
AAAPT member benefit

(*LOCI*) project (1973–80) Dave Brooks, Sam Treves, Laird Thompson, Ed Schmidt, Ed Zimmerman; *Comprehensive Approach to Undergraduate Science Education (CAUSE)* (1979–82) Dave Brooks, Cliff Bettis; *The Puzzle of the Tacoma Narrows Bridge Collapse videodisc* (1979–82) Dean Zollman, Tom Campbell, NETV Videodisc Design/Production Group, Barney Elliott, Dorothy Derringer, Gary Carlson, Tom Tipton; *Junior high Skylab physical science project* (1979–81) Tom Campbell, Dean Zollman; *Centennial Education program* (1979–81) Annetta Young, Marilyn McDowell, Jerry Petr, Elizabeth Carpenter, Frances Kaye, Dani Weinberg, Don Cunningham, Patrice Berger, Luiz Perdomo, Terri Nygren, Jim Michel, Bob Bergstrom, Patrick Hill, Arnie Strassenberg; *Control Data Corporation Physics lessons* (1980–82) Pat Ridgely, Carl Tomizuka, Ed Gibson, Richard Herr; *University of Nebraska Computer-based Learning Experiment (UNCLE)* (1982–83) Clifford Bettis, Dave Winch, Paul Menter, Bruce Oberg; *Annenberg/CPB Videodisc project two physics videodiscs* (1982–84) Dean Zollman, Jack McBride NETV Videodisc Design/Production Group, Dave Brooks, William Leonard, Tom Tipton; *Developing Student Confidence in Physics Workshop for AAPT* (1982–85) Gary Allen, Dean Zollman, Damian Nichols, Arnold Strassenberg, Judy Aubrecht, Jeffrey Mallow, Susan Agruso, Carol-ann Tripp; *British Open University—"Teddy Bear" videodisc* (1982–83) David Blackburn, Tony Bates, Diane Laurillard, Keith Williams, Paul Blenkhorn, Martin Wright; *Tandy computers in physics curriculum project* (1986–88) Ed Jones, Cliff Bettis, Bob Hardy; *Physics Demonstration/Laboratory Institutes for High School Teachers* (1986–88) Charles R. Lang and Westside High School staff, Bob Klein, Pete Adwers, John Rogers, Doug Wilson, Jack Skrocky, Cliff Bettis, almost 100 high school physics teacher participants including Deb Beightol and Jan Greiner; *Skylab Physics videodisc* (1986–87) Rick Swanson, Sgt. Horne, DFSIV, Dean Zollman; *Science of Flight videodisc* (1987–88) Rick Swanson, Sgt. Horne, Keith Williams, George Hept; *Wondering About Physics...Using Spreadsheets to Find Out, What If? and Physics Vignettes* (1986–88) Dewey Dyk-

stra, John Wiley and Sons, Inc.; *Guilty or Innocent? Superstack award winning HyperCard lesson* (1988) Dave Winch, Karl Armstrong, Andrew Fuller; *Physics: Cinema Classics project* (1989–92) Chuck Lang, Dean Zollman, Carol-ann Tripp, Dave Winch, NETV Videodisc Design/Production Group, Marilyn McDowell, Allen Specht, Brenda West, Michelle Mason, John Dowling, Donna Willis, AAPT; *New Careers in Science for Rural Girls in Nebraska & Young Scholars Institutes* (1989–1991) Nan Lindsley-Griffin, Jan Wright; *Bridges, Bicycles and Traffic—Thematic Physical Science Lessons* (1989–date) Dean Zollman, Charles Lang, Carol-ann Tripp, Ton Ellermeijer, several other physicists and physics teachers in The Netherlands, Leendert Kersten; *Transforming Physics Content Using New Technologies USAFA* (1990–92) Dean Zollman, Dave Winch, Glenn Sowell, Rolf Enger, James Head, Marilyn McDowell, Margaret Fuller, and 35 participants, including Marvin De Jong, Gregor Novak, and Doyle Davis; *Physics Teacher's CD-ROM Toolkit project* (1991–date) Dean Zollman, Evelyn Tuska Patterson, Jan Tunison, Michelle Mason, Laurie Gottsche, Chuck Lang, Courtney Willis, Debra Beightol, Carol-ann Tripp, Jan Greiner, Tim Ingoldsbey, Rolf Enger, Jacqueline Spears, Marilyn McDowell, Gerhard Salinger, UNL, and KSU Student Helpers; *New Technologies to Improve Physics Laboratories project* (1991–date) Gregor Novak, Doyle Davis, Linda McDonald, Larry Martin, Evelyn Tuska Patterson; *Using New Technologies to Teach Physics USAFA* (1991–date) Evelyn Tuska Patterson, Glenn Sowell, Dave Winch, Marvin De Jong, James Head, Rolf Enger, Marilyn McDowell, Margaret Fuller, and 39 participants; *Creating CD-ROMs for Science Education Conference* (1992) Marilyn McDowell, Jan Tunison, Harmon Tunison, Michelle Mason, Evelyn Tuska Patterson, and conference participants including Mary Budd Rowe, Gregory Rawlings, Gerhard Salinger, Kathy Fuller, Mary Miller, and Dave Brooks; *Improving physics laboratories for bioscience students* (1992–date) Evelyn Tuska Patterson, Doug Zbylut, Jack Morris, and Eric Davies.

A magnetic suspension system for atoms and bar magnets

C. Sackett, E. Cornell, C. Monroe, and C. Wieman

Joint Institute for Laboratory Astrophysics and the Department of Physics, University of Colorado, Boulder, Colorado 80309-0440

(Received 21 January 1992; accepted 20 September 1992)

A three dimensional magnetic confinement system is presented which will trap both macroscopic and atomic magnetic dipoles. The dipole is confined by dc and oscillating magnetic fields, and its motion is described by the Mathieu equation. Most aspects of the dynamics of the trapped objects depend only on the ratio of the magnetic moment to the mass of the dipole. Similar motion was observed for masses varying over 21 orders of magnitude (from 1 atom to 0.2 g). The trap is constructed from inexpensive permanent magnets and small coils which are driven by 60 Hz line current. The design of the trap as well as the behavior of the trapped particle are discussed herein.

I. INTRODUCTION

People have always been fascinated by the sight of an object suspended in space, free from contact with any material substance. Demonstrations of such an event are often the centerpiece of magic shows, NASA public relations, and presentations on high temperature superconductivity. Recently, atomic physicists have developed a particular interest in these phenomena. Their work would probably make an excellent magic trick for a stage act, but is of

course well grounded in physical theory. Electric or magnetic fields, produced by some relatively distant source, are used to suspend and confine isolated ions, electrons, and atoms. When confined in this manner, the particles are free from the usual perturbations produced by nearby atoms, and thus can be studied with unprecedented precision. The Nobel prize in physics was awarded to Dehmelt and Paul for their pioneering work in the field of ion trapping. While trapping of charged particles is a mature field, the trapping of neutral particles using magnetic fields is more difficult

and very new. A significant development in this field was the recent demonstration of a new type of trap which uses an oscillating magnetic field gradient to trap cesium atoms by interacting with their magnetic dipole moments.^{1,2}

We realized that the behavior of a particle in such a trap depends only on the ratio of the magnetic moment to mass, and not on either individually. Since macroscopic ferromagnetic dipoles can have moment to mass ratios which are comparable to or larger than that of an isolated cesium atom, this suggests that an ac trap could be used to trap a macroscopic magnet. We are interested in this macroscopic magnet trap for three rather unrelated reasons. First, a large scale model provides an excellent demonstration of the atom trapping technique and is a helpful pedagogical aid. Second, the technique is a new method of magnetic suspension and confinement. It has several advantages over previous techniques, and so might prove useful in other applications. Finally, the physics of the system is interesting, and merits study for its own sake.

In this paper, we first discuss the problem of magnetic confinement in general, and the theory for our particular trap. We then describe our apparatus, and the constraints upon its design. In the final section, we discuss the behavior of the system, and compare it with theory.

II. MAGNETIC TRAPS

Consider the problem of confining an uncharged magnetic dipole in three dimensions. In a magnetic field \mathbf{B} , a dipole with moment $\boldsymbol{\mu}$ has a potential energy $-\boldsymbol{\mu} \cdot \mathbf{B}$. The principle of virtual work may be used to find the force on the dipole, say $-F_z dz = dU = -d(\boldsymbol{\mu} \cdot \mathbf{B}_z)$. In general then, the result³ is $F = \nabla(\boldsymbol{\mu} \cdot \mathbf{B})$. For an ordinary bar magnet placed in a slowly changing field, $\boldsymbol{\mu}$ will align itself with \mathbf{B} , so that $\boldsymbol{\mu} \cdot \mathbf{B}$ becomes $|\boldsymbol{\mu}| |\mathbf{B}|$, and the magnet will be accelerated in the direction of increasing field magnitude by a force $|\boldsymbol{\mu}| |\nabla|\mathbf{B}||$. Hence, the dipole would be stably confined at any local maximum in $|\mathbf{B}|$. Unfortunately, Maxwell's equations prohibit such a maximum in free space.⁴

Although a bar magnet cannot be trapped in free space using a purely static magnetic field, there are several alternative approaches to confinement. Perhaps the simplest is to magnetically confine the dipole in one or two dimensions, using some other force in the remainder. A common example of this is the toy in which a ring magnet is placed around a hollow tube. When a smaller magnet is placed inside the tube, the field confines it to the plane of the ring, and the tube prevents it from sticking to the side of the magnetic ring. Although the small magnet is confined, the presence of contact forces is undesirable in many cases.

Another way to trap a magnetic dipole in a static field is to have it spinning. If the angular momentum of the object is non-negligible, and aligned with the dipole moment, the dipole will tend to precess about the magnetic field, at some fixed angle. If we set the system up with $\boldsymbol{\mu}$ and \mathbf{L} antiparallel to the field, the dipole will be attracted to a minimum in $|\mathbf{B}|$. Field minima of this sort can occur, so this is a physically realizable method of confinement. Although it is difficult in practice to work with a rapidly spinning macroscopic object, the technique may be readily applied to an atom, where the projection of spin onto \mathbf{B} is quantized. Spin polarized atomic gases have, in fact, been confined in such "weak field seeking state" traps.⁵

Finally, a dipole may be confined in a dynamic field. An example of this is the (rather more expensive) toy which magnetically suspends an object, but uses optical sensors and a feedback mechanism to continually adjust the field so as to correct for the instability of the static equilibrium. Systems of this type require complicated electronics, and though they may provide a nice example of feedback and control systems for the engineer, they are not particularly interesting to the physicist.⁶

This article presents a quite different dynamic method, which uses sinusoidally oscillating magnetic fields. The technique is similar to the Paul trap for ions, in which an oscillating electric potential can be arranged in such a way that the motion of an ion in the field is stable.⁷ The trapping mechanism of such dynamic traps is analogous to the confinement of a marble placed at the center of a rotating saddle. Along any given direction, the marble is alternately attracted to and repelled from the center. If the saddle is rotating fast enough, the marble will not have time to roll off before being pushed back, and will be stably confined. A dipole placed in a suitable alternating magnetic field can be similarly confined, as shown in the next section.

A trap of this nature was first developed using pure electric fields, to trap ions. The magnetic version was first proposed by Lovelace and Tommila for use with atomic hydrogen.² Electrodynamic traps for macroscopic particles have also been built, most recently by Winters and Ortjohann.⁸

III. THEORY OF ac MAGNETIC CONFINEMENT

Our trap, like the Paul (or "rf") ion trap, holds a particle in an oscillating quadrupole potential. We achieve this using an axially symmetric magnetic field

$$B_z(r,z,t) = B_{oz} + 1/2 (k_{dc} + k_{ac} \cos \Omega t) (z^2 - r^2/2), \quad (1a)$$

$$B_r(r,z,t) = -(k_{dc} + k_{ac} \cos \Omega t) zr, \quad (1b)$$

where $k_{dc} = d^2 B_z^{dc}/dz^2$ and $k_{ac} = d^2 B_z^{ac}/dz^2$ are the curvatures of the constant and oscillating components of the field, respectively. If the constant B_{oz} is much larger than all other terms, the magnitude of the field can be approximated by B_z , and the field direction will be predominantly axial and constant in time. A dipole placed in the field will align its moment with \mathbf{B} and experience a force $|\boldsymbol{\mu}| (\nabla B_z)$. The resulting classical equations of motion can be cast in the form of Mathieu equations

$$d^2 x_i / dT^2 + (a_i + 2q_i \cos 2T) x_i = 0, \quad x_1 = rx_2 = z, \quad (2)$$

where m is the mass of the particle, $a_z = 4\mu k_{dc}/m\Omega^2$, $q_z = 2\mu k_{ac}/m\Omega^2$, $a_r = -a_z/2$, $q_r = q_z/2$, and $T = \Omega t/2$. Solutions to the Mathieu equation are described in various references.⁹ The important fact is that the solutions are bounded for certain values of the coefficients a and q . Physically, this means that if the frequency Ω and curvatures k_{dc} and k_{ac} are adjusted properly, the dipole will be confined. We use the relationships $a_z = -2a_r$, $q_z = 2q_r$ to determine regions of the a_z - q_z plane where the stability condition is met for both the axial and the radial coordinates simultaneously. If a_z and q_z lie in one of these "stability regions," the dipole can be confined in three dimensions. A graph of the experimentally most convenient stability region is shown in Fig. 1.

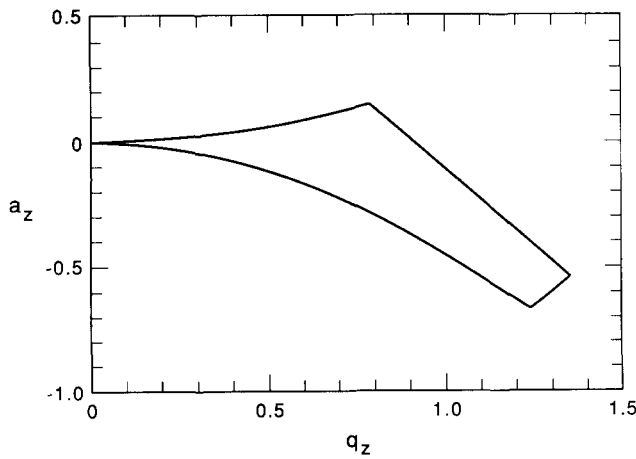

Fig. 1. The stability region of the a_z - q_z plane. Solutions of the Mathieu equation are governed by the parameters a and q , which are proportional to the curvature of the dc and ac fields, respectively. For certain values, solutions exist which will be bounded for all time, while for other values all solutions diverge to infinity. The relationship between the parameters for the various components allows the motion to be completely characterized by one pair of values, a_z and q_z . Plotted is one of the regions of the a_z - q_z plane for which particle motion will be confined in all three dimensions.

Even when stable, the motion of the dipole is complicated. For small q , we can approximate the solution of Eq. (2) by

$$x(T) = A(1 + q/2 \cos 2T) \cos \beta T, \quad (3)$$

where, to fourth order in q ,

$$\beta^2 = q^2/2 - a. \quad (4)$$

In each dimension, then, the motion consists of a large slow oscillation at frequency $\omega_0 = \beta\Omega/2$, on which is superposed a small rapid oscillation at the driving frequency Ω . It is conventional in the ion trapping literature to refer to these separate components as the secular motion and micromotion, respectively. The secular motion is that of a particle placed in a harmonic potential well with spring constant $m\omega_0^2$, while the micromotion is a smaller oscillation at the frequency of the ac field and with amplitude that varies with time, proportional to the secular displacement.

We originally constructed this sort of trap to contain cesium atoms. After successfully doing so, we noted that the essential parameters a and q depended only on the ratio of magnetic moment to mass. Since macroscopic ferromagnets can have a moment to mass ratios comparable to that of an individual atom, this trap can work for a bar magnet in essentially the same way as for an isolated atom. Differences between the microscopic and macroscopic system arise in several possible ways. First, if the object to be trapped is reasonably large compared to the trap itself, the magnetic field will vary somewhat across the object. Thus the cohesive forces holding the object together will effect its motion. Second, if the object is metallic, screening currents will be induced which will change the field inside the material. Skin depths for good conductors at 60 Hz are a few millimeters, so this effect will be important for an appreciably sized object. Finally, the object to be trapped may be

constructed of a material with permeability not equal to one, which will again change the field within the object.

IV. APPARATUS

To stably confine a particle with a given ratio of magnetic moment to mass μ/m , the magnetic field must meet several requirements. It must have dc and ac components with (1) a dc magnitude large compared to the ac magnitude; (2) a dc gradient to balance gravity, $d|\mathbf{B}|/dz = mg/\mu$, at a position of small or zero ac gradient; and (3) an ac frequency Ω , axial dc curvature k_{dc} , and axial ac curvature k_{ac} such that the parameters a_z and q_z lie in the region of stability shown in Fig. 1.

We were faced with several additional practical constraints. As the device was intended to be a demonstration model, it had to be reasonably portable and to not require bulky power supplies. Therefore we chose $\Omega/2\pi = 60$ Hz, and used permanent magnets to produce the dc field. It was also desirable that the confinement region be clearly visible. Finally, for simplicity we did not want to use water or forced air cooling of the ac coils; thus the rate of heat dissipation limited the amount of current we could use.

The values of a_z and q_z both depend on the moment to mass ratio, μ/m . The design of the apparatus therefore depends on the specific material to be trapped. A larger ratio is desirable because it requires smaller fields for a given trap depth. We therefore use fragments of a commercially available Nd/Co/Fe alloy magnet, with moment to mass ratio of roughly 100 erg/G/g, about 2.5 times that of a spin-polarized cesium atom. The fragments are irregularly shaped since they are obtained by chipping pieces off of a larger magnet. Less expensive materials, with lower mass to moment ratios, could certainly be used, but would require proportionally more driving current. This would be feasible in a water-cooled system.

The precise determination of μ/m for these fragments is difficult, but for purposes of designing the trapping fields, various simple measurements suffice. A technique we find convenient is to run dc current through a large coil of known dimensions, and measure how much current is needed to lift the fragment against gravity. We then know the field gradient required to cancel gravity, from which we determine μ/m .

The final design used to meet these constraints is sketched in Fig. 2, and described in detail in the Appendix. It consists of three ring-shaped permanent magnets and a coil assembly. The two larger magnets are iron, and are mounted 1.50 in. above and 1.69 in. below the trap center, so that their fields add but their gradients nearly cancel. The third magnet is a thin ring of plastic magnet, mounted 0.2 in. above the plane of the trapping region. It is used to finely adjust the field curvature and gradient. The combined dc field of the assembly at trap center was predominantly axial, with $B \approx 150$ G, $dB/dz \approx 10$ G/cm, and $d^2B/dz^2 \approx 8$ G/cm².

A dc curvature of 8 G/cm² and a μ/m of 100 (erg/G)/g makes a_z equal to 0.02. We see in Fig. 1 that q_z must be at least 0.2, which requires an ac curvature of 160 G/cm². In order to provide this curvature while insuring that the ac field be small relative to the dc field, we use a set of four coils symmetrically mounted in pairs and connected in series. The current sense of the outer pair is opposite the sense of the inner pair, so that their respective ac fields nearly cancel at the trap center, while their positioning was

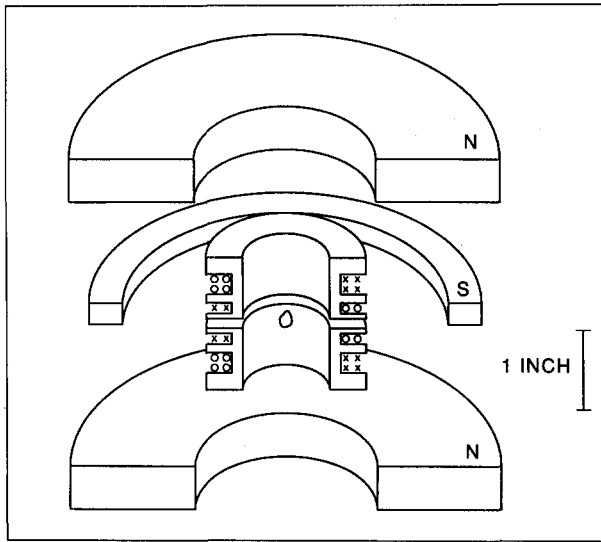

Fig. 2. Arrangement of magnets and coils in the trapping apparatus. The two large permanent magnets on the top and bottom provide a large field at trap center, while the magnet in the center provides a small correction to the gradient and curvature. Coils are driven with 60 Hz ac current, in the sense indicated.

such that the ac curvatures added. We calculate that the coils provide an rms magnitude per applied current of 2.6 G/A, and a curvature of 41.4 G/cm²/A. Powered by a Variac, the coils can maintain an ac current of up to 9 A rms without burning the insulation on the wires.

Although constructing the trap was not difficult, loading it presented a challenge. The magnetic fragment must be inserted through the large fringing fields of the coils and magnets, and released at the proper position with the correct orientation. We do this by holding the fragment in nonmagnetic forceps. The orientation is set by placing the fragment on top of the upper permanent magnet, and then grabbing it with the forceps held vertically. A simple jig is then used to position the forceps so that the fragment is held in the center of the trap, where it is released. We found that the fragments tended to stick to plastic forceps, but that copper (and presumably any other nonmagnetic metal) works adequately. Because it is difficult to release a fragment exactly at rest in the center of the trap, it is easiest to turn the current up to 6 A for loading. Once the initial motion caused by loading has been damped out by air resistance, the trap current may be gradually reduced to as low as 3.5 A. All of the authors have been able to repeatably load fragments up to 5 mm in diameter, and one (C.A.S.) has loaded fragments of nearly 1 cm. Tinkering with the position of the shim magnet (part B in Fig. 5) is sometimes required.

Larger fragments do not require more current than smaller ones, but are more difficult to load. One source of difficulty is that large fragments must be positioned more precisely than smaller ones, since they occupy a large fraction of the trapping region. However, this is somewhat compensated for by the fact that the micromotion forces in large fragments can be felt through the forceps. The fragment may then be positioned by feeling the decrease in the vibration at trap center. Loading is also difficult because as the fragment is inserted into the trap, it must closely pass one of the large permanent magnets. For larger fragments,

the forces felt in this process are significant, and tend to pull the fragment out of the forceps. Finally, the nonidealities mentioned at the end of Sec. III become significant for fragments larger than a few millimeters.

V. BEHAVIOR OF THE TRAPPED MAGNET

As shown in Sec. III, a magnet in an ac magnetic trap is expected to execute simple harmonic secular motion, on which is superposed a small vibration at the driving frequency. The motion of a relatively large fragment, for which approximation as a point dipole is not accurate, is considerably altered. The motion is quite complicated and fascinating, but is difficult to describe quantitatively. However, for small perturbations from equilibrium, it did prove possible to analyze the frequency spectrum of the motion. This analysis, as well as a qualitative description of the motion, is presented below.

The motion of a trapped fragment is not simple, even for very small amplitude motion. It depends strongly on the details of the excitation, but in general is characterized by strong coupling between the two horizontal translational modes and the various rotational modes. This coupling is presumably due to variation in trapping forces across the fragment, as well as irregular torques produced by air resistance. As an additional complication, the fragment is essentially free to rotate about its magnetic moment vector, which is not necessarily along a principle axis and thus couples to other motions. Damping by air resistance occurs on a time scale of approximately a minute, but varies with the size and shape of the fragment. The micromotion is barely perceptible by eye, showing up as a fuzziness in the profile of the fragment when it is displaced from the center.

The volume in which the particle was stably confined was disk shaped, roughly 1 mm high in the axial direction and up to 2 cm radial diameter. The size of this disk was observed to decrease as the ac curvature was increased.

To study the frequency components of the motion, a HeNe laser was used to illuminate the fragment from the side, so that the shadow of the fragment moved across a photodiode. We then took a Fourier transform of the output of the photodiode. A sample spectrum for a secular amplitude of approximately 0.5 mm is shown in Fig. 3. Rewriting Eq. (3) as separate frequency components, we obtain

$$x_i(t) = A \left(\cos \beta_i \Omega t / 2 + q_i / 4 \cos [1 - \beta_i / 2] \Omega t + q_i / 4 \cos (1 + \beta_i / 2) \Omega t \right). \quad (5)$$

So, if we examine the spectrum near $\Omega = 60$ Hz, we expect to see two pairs of sidebands; one at the axial secular frequency β_z and one at the radial frequency β_r . The two outer pairs of sidebands in Fig. 3 correspond to these frequencies, the axial being the outermost. The innermost pair of sidebands is due to axial rotation, while the peak at 60 Hz itself is due to misalignment of the trap components so that the point at which the dc gradient exactly cancels gravity does not lie at the center of the ac coils. The equilibrium position therefore has a slight secular displacement and corresponding 60 Hz micromotion. For larger secular oscillations the Fourier spectrum rapidly becomes more complex, and individual components are impossible to identify.

By varying the ac current, the various secular frequencies can be changed. The axial and radial frequencies may then be used to determine a_z and q_z by inverting Eq. (4).

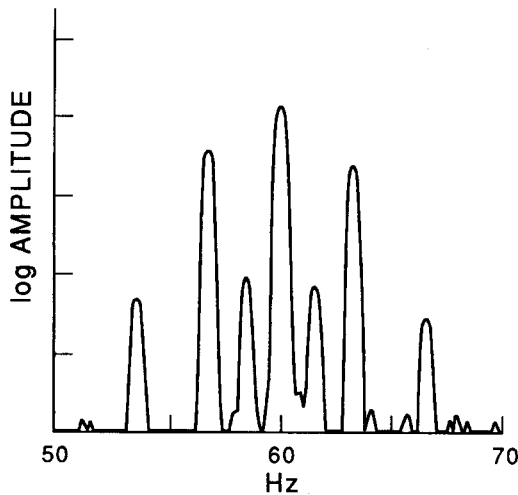

Fig. 3. Frequency spectrum of fragment motion for small perturbation. The two outer pairs of sidebands are the axial and radial secular oscillation. The inner sidebands are due to axial rotation, and 60 Hz peak is an artifact of trap misalignment.

Figure 4 shows an expanded graph of the stability region in the a_z - q_z plane, with our data plotted for several ac currents. Since $a_z = 4k_{dc}/m\Omega^2$ does not depend on the ac field, we expect a variation in the ac current to change only q_z , so that the points in Fig. 4 should lie on a horizontal line. That they do not is probably due to the misalignment of the permanent magnets. If they are imperfectly aligned, so that the dc field gradient does not exactly cancel gravity at the center of the ac coils, the equilibrium position of the fragment is displaced. The amount of this displacement depends on the ac fields, so varying the ac current alters the equilibrium position of the particle. The dc curvature k_{dc} also varies with position, so that a_z will vary slightly with ac current.

One additional aspect of the trap which we found interesting was the possible use of eddy currents to damp out

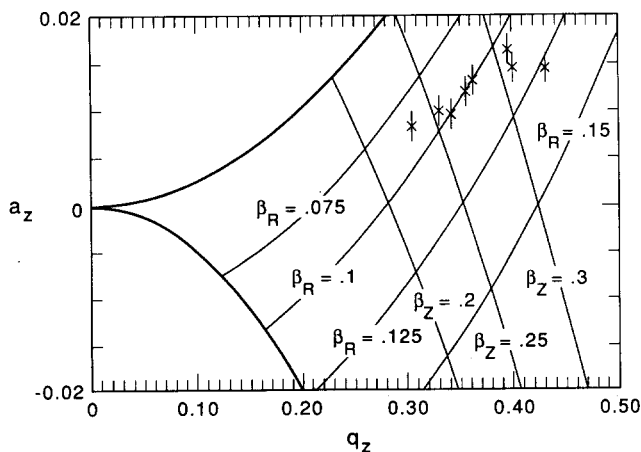

Fig. 4. Expanded section of Fig. 1, showing points at which trap has been operated. Contours show lines of constant β . Different data points correspond to different ac currents, and hence different values of q_z . We expect, then, that the points should lie on a horizontal line. The anomalous variation in a_z is due to trap misalignment.

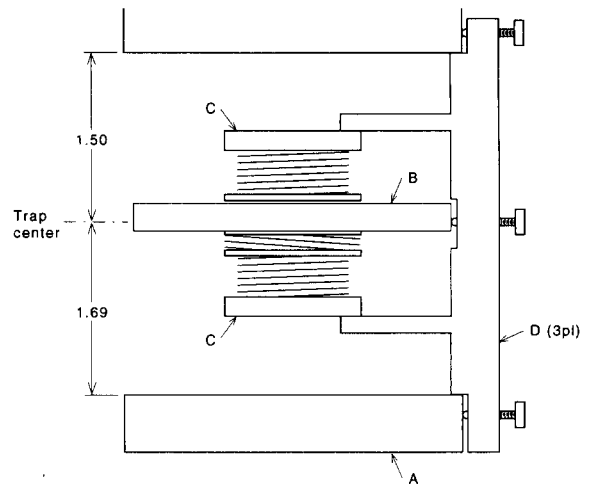

Fig. 5. Drawing of the apparatus. Dimensions are in inches. Parts A are toroidal iron magnets, with outer diameter 2.9, inner diameter 1.2, and thickness 0.5. Part B is a trim magnet with OD 2.6, ID 2.1, and thickness 0.25. The position of part B relative to trap center is adjustable by set screws. Parts C are the coil assembly, shown in detail in Fig. 6. Parts D are three aluminum support posts, bolted to parts C.

secular motion. This effect is quite dramatic, and can be observed by placing a copper plate near the fragment. When the plate was placed about a millimeter from the center of a small fragment, the damping time decreased from over 1 min to 0.25 s.

VI. CONCLUSION

We have constructed a magnetodynamic trap, capable of confining a 0.2 g object in three dimensions. The trap is constructed of simple, low cost materials, and requires only 50 W of power at 60 Hz. The behavior of a trapped particle is described reasonably well by the Mathieu equation.

The capacity of our trap is limited by the rate of power dissipation, with lower ratios of magnetic moment to mass requiring proportionally greater ac current and stronger dc magnets. The apparent limit on the size object our trap can contain is the size of the trap itself, although the behavior of larger objects will likely be less precisely modeled by the Mathieu equation. Since larger coils require more current to produce the same curvature, more efficient power dissipation would enable the trap to hold both larger objects and less magnetic materials.

We perceive the primary value of the trap to be pedagogical, as it provides a fascinating example of physics accessible to the undergraduate student. It is one of relatively few experiments based on purely classical mechanics suitable for an advanced physics lab. At the same time it demonstrates a technique which is being used currently in the trapping and cooling of neutral atoms. If designed as a fixed lab apparatus instead of a portable demonstration model, several drawbacks of the trap could be remedied. A water cooling system for the ac coils would allow exploration of the high curvature regions of the stability diagram. The use of a dc coil rather than permanent magnets to supply the required dc field would provide a second adjustable parameter, while also allowing fine corrections of the field alignment. We feel that after improvements such as

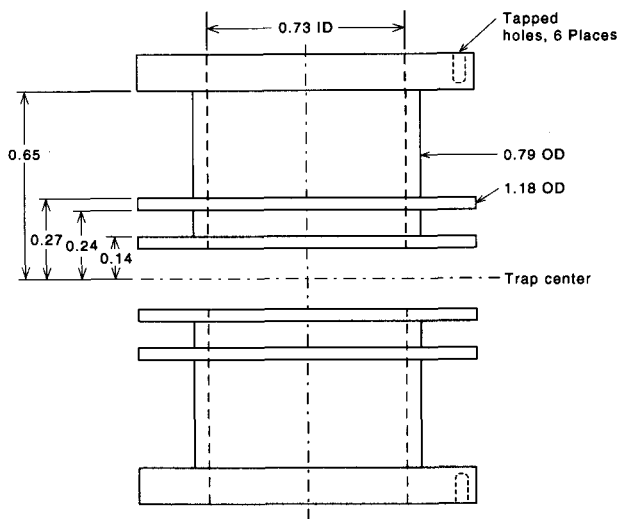

Fig. 6. Mechanical drawing of coil assembly. Dimensions in inches, with only critical dimensions shown. Wire coils are wound within the channels. Tapped screw holes are located equilaterally about the top and the bottom coil form.

these are made, the trap will make an excellent, and inexpensive, addition to the undergraduate laboratory repertory.

ACKNOWLEDGMENTS

This work was supported by the Office of Naval Research and the National Science Foundation. C.S. acknowledges a fellowship from the National Science Foundation.

APPENDIX: DESIGN SPECIFICATIONS

For readers wishing to duplicate our apparatus, we describe our final design. A scale drawing of the apparatus is shown in Fig. 5.

The main permanent magnets we used (parts A in Fig. 5) were obtained from Edmund Scientific, part number A37,621 at \$7.00 each. The trim magnet (part B) was cut to shape from a sheet of flexible magnetic material. The material is soft and can easily be cut by a variety of means.

A drawing of the coil forms used (part C) is shown in

Fig. 6. The forms were constructed of aluminum, and wound with 22 gauge copper magnet wire, with 44 turns in the larger grooves and 24 turns in the smaller. The four coils are connected in series, and the two large grooves should be wound in the same direction, and the two smaller grooves in the opposite direction. The coils can be powered by running line voltage through a low-current variable transformer, providing say 2 A at 0 to 120 V. This current is then fed to a step down transformer, which yields 20 A at 0 to 12 V. The appropriate transformers can be obtained from any electronics supplier, at a cost of around \$80. Adjustability of the current is not strictly necessary for the operation of the trap, so if cost is a significant constraint, a single transformer, or even a lamp bank could be used to power the coils.

The coils and magnets are held in place by three aluminum supports, placed axially around the trap. One of the supports is shown in Fig. 5 (part D). A 1/2 in. diam aluminum post was attached to one of the supports, and used as a jig to position the forceps when loading the trap. The jig was constructed by attaching a screw to the forceps, and mounting them on an (aluminum) optical post. The forceps assembly was then mounted on the large post using post clamps, obtainable from an optics supplier.

- ¹E. A. Cornell, C. Monroe, and C. E. Wieman, "Multiply loaded, ac magnetic trap for neutral atoms," *Phys. Rev. Lett.* **67**, 2439-2442 (1991).
- ²R. V. E. Lovelace, C. Mehanian, T. J. Tommila, and D. M. Lee, "Magnetic confinement of a neutral gas," *Nature* **318**, 30-35 (1985).
- ³R. P. Feynman, R. B. Leighton, and M. Sands, *The Feynman Lectures on Physics*, (Addison-Wesley, Reading, MA, 1964), Vol. II, Sect. 15-1.
- ⁴W. Ketterle and D. Pritchard, "Trapping and focusing ground-state atoms with static fields," *Appl. Phys. B* **54**, 403-406 (1992).
- ⁵V. S. Bagnato *et al.*, "Continuous stopping and trapping of neutral atoms," *Phys. Rev. Lett.* **58**, 2194-2197 (1987); A. Migdall *et al.*, "First observation of magnetically trapped neutral atoms," *Phys. Rev. Lett.* **54**, 2596-2599 (1985).
- ⁶See, for example, the 1992 Edmund Scientific Company catalogue, p. 177.
- ⁷F. G. Major and H. G. Dehmelt, "Exchange-collision technique for the rf spectroscopy of stored ions," *Phys. Rev.* **170**, 91-107 (1968).
- ⁸H. Winter and H. W. Ortjohann, "Simple demonstration of storing macroscopic particles in a Paul trap," *Am. J. Phys.* **59**, 807-813 (1991).
- ⁹*Handbook of Mathematical Functions*, edited by M. Abramowitz and I. A. Stegun, Applied Math Series Vol. 55 (National Bureau of Standards U.S., Washington DC, 1966), pp. 721-751; (reprinted by Dover, New York, 1965.)

NEWTON AS A LECTURER

So few went to hear Him, & fewer y^f understood him, y^f oftimes he did in a manner, for want of Hearers, read to y^e walls.

Humphrey Newton, quoted in *Let Newton Be*, edited by John Fauvel, Raymond Flood, Michael Shortland, and Robin Wilson (Oxford, New York, 1988), p. 16.